



# Developing an Immersive Multi-Projection System with Hybrid Screen

Jaeho Ryu, Naoki Hashimoto, Shoichi Hasegawa and Makoto Sato

Precision and Intelligence Laboratory Tokyo Institute of Technology  
4259 Nagatsuta, Midori-ku Yokohama, 226-8503 Japan  
{jaehoryu,naoki,hase}@hi.pi.titech.ac.jp, msato@pi.titech.ac.jp

## Abstract

This is a study about a new multi-projection display system, D-vision, which has hybrid screens. In D-vision, we use a tiled-projection system which is composed of twenty four patches of projection, sixteen of which are used for front projection on the peripheral area of the screen and eight of which are used for rear projection on the central area of it. The screen consists of differently shaped surface elements that are the partial surfaces of such objects as planes, spheres, cylinders and tori. In this paper, we illustrate the following technologies: the distributed rendering PC cluster system, the Turntable as the walking interface for navigation, Big-SPIDAR as the string based force feedback interface for interaction, and stereoscopic viewing for motion parallax and so forth. Now we are concerning with the upgrade of application of D-vision for the virtual world experience. We carried out a experiment about the sense of presence to explain the effects of wide FOV(field of view) including floor projection as the factor of immersion.

**Key words:** virtual reality, immersive projection technology, multi-projection, stereoscopic viewing, sense of presence

## 1. Introduction

Recently, there are many of researches about the multi-screen immersive display system. In this kind of VR system, covering an audience's whole field of view with as many projectors as possible is very important to provide an immersive viewing experience with high-resolution image. The super-wide display can be found in the entertainment system that can present the audience with the feeling like he is actually within a virtual world. We can also find some applications of human scale immersive display system in the manufacturing industry that enhances the efficiency of produce procedure.

However, there are several problems need to be solved in

that immersive display systems. First, the shape of the screen is a problem. As the first immersive display, CAVE [1] which was developed at the university of Illinois, has four 10x10 feet screens placed at front, bottom, left, and right side. The each screen presents high immersion by its own stereoscopic image. The CABIN [2] added the ceiling screen and the COSMOS [3] added the back screen that covered all directions of the viewer finally. Theses researches were focused on presenting the audiences with the wide-angle view. They have the simple shape of screen face, but on the contrary, the hard edges that are made from the orthogonal joint by screens have some problems. In order to show the accurate image to the viewer without distortion, these systems need precise head tracking techniques that is hard to be completed. Therefore, the distortion of the joint area is a still big problem for these immersive displays.

On the other hand, the curved screen was also developed for the immersive display systems [4][5]. The curved screen has the continued joint area that can show the clear image to the audiences without notification of that part. But, it is hard to focus the image on the curved screen because of the characteristic of its shape. Furthermore, the requirement of the high-speed rendering system to calculate the distortion image for the curved screen is another big problem. Theses are the demerit points of the curved screen when the clearly focused image is required. Therefore, to select the curved display system is not so easy for these reasons.

Moreover, there are also some problems in creation and projection of the high-resolution images on the hybrid screen. The limited performance of the projector in the resolution and brightness disturbs to make super-wide screen. Also, in order to calculate the computer graphic of high-resolution images in real-time, we need high performance of computer. In pervious systems, the graphic workstation is a common selection for the VR system for above reason. Nowadays, it is not any more reasonable choice to install and maintain such a system.

There is a strong request to make more efficiency display system without these problems. We developed a new immersive display system, “D-vision”, based on the new concepts from the past. One of the main characteristics of the D-vision is the composition of the multiple screens.

It has the high resolution flat screen like the CAVE for the central view of eye. In the peripheral view of eye, it has curved screen for the super-wide view that helps high immersion experience. By merging of those two kinds of screens, we constructed an efficiency screen display system that is more suitable for human eye. We used the multi-projector technology for the projection on the hybrid screen. In the creation of the image, twenty-four PCs are used. Those images created in the each PC are sent to LCD projector to be projected on the screen. The images are corrected by our original image processing hardware to realize highly immersive virtual environment. The Fig. 1 shows the whole structure of the D-vision.

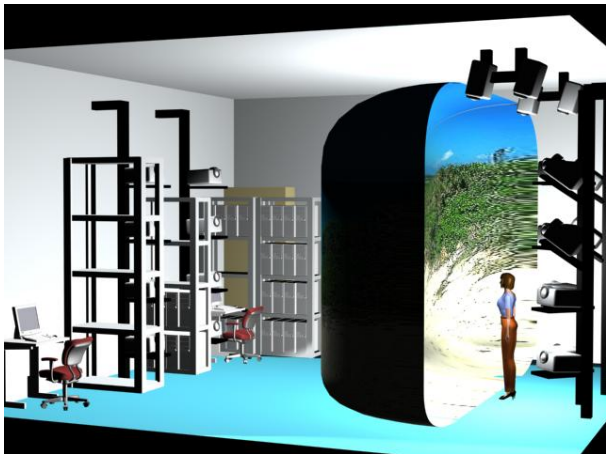

Fig. 1 Concept of the D-vision

In the aspect of the installation space, the Dvision requires the smaller room space compared with other VE systems. The D-vision needs total 4.5m(height) x 6.5m(width) x 7.0m(depth) room dimensions including the distributed computer system, the projectors and other interface devices. Although the CAVE, the most common VE system, is lack of the ceiling projection, it requires the approximately 4.0m(height) x 9.0m(width) x 6.0m(depth). To think about the CAVE is four screen system, the CABIN and COSMOS systems that are added one and two more screens to the system composition naturally require more room space to install the additional projectors and structure frame. The 5 screen system, CABIN, requires the 7.0m(height) x 7.0m(width) x 7.0m~10.0m(depth) room dimension with 2.5m x 2.5m screens. The total installation space for the CABIN is larger than D-vision. The COSMOS, CAVE-like 6 screen display system, need more space than CABIN. However there are a lot of characteristics of the each screen systems to be considered for the comparison, the smaller

installation space for the VE system is one of the merits of our system.

## 2. System Organization

The display system we developed was designed as a visual component of a system that provides a virtual experience with physical force feedback brought about by a wire driven force display subsystem [6] and a locomotion interface subsystem using a computer controlled turntable. Our screen design attempted to satisfy the following four conditions: (1) to completely cover a viewing area, (2) to extend its size as far as possible within the limit of the space available, (3) to make the shadow cast by the viewer as small as possible, and (4) to enable stereoscopic image projection.

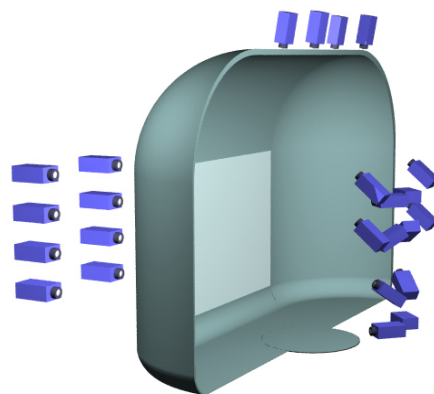

Fig. 2 Hybrid screen composed of differently shaped surface elements and twenty-four projectors installed to cover the entire surface of the screen.

As shown in Fig. 2, the resultant screen is 6.3 meters wide, 4.0 meters high, and 1.5 meters deep. The central flat part of the screen is for rear projection with eight projectors with SXGA, 1280x1024 pixels resolution.

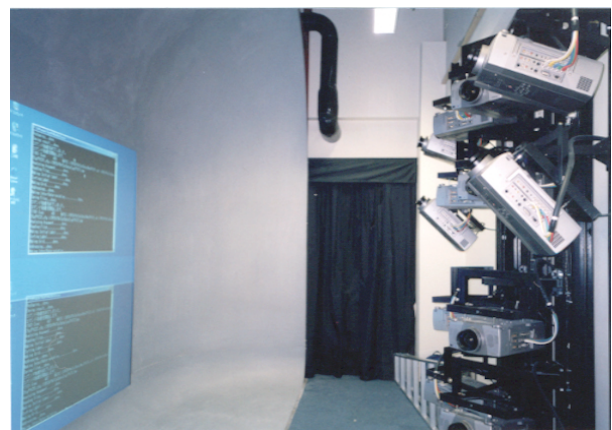

Fig. 3 Front side view of the display system

The remaining part of the screen is for front projection with sixteen projectors with XGA, 1024x768 pixels resolution. The projectors were set up at the positions indicated in Fig. 2, and Fig. 3 shows the projectors for front projection mounted on posts.

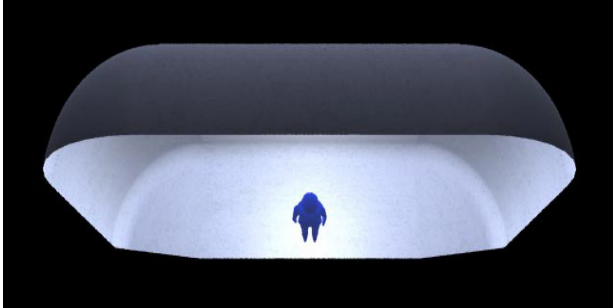

Fig. 4 Position for the viewer when a virtual reality environment is provided

As previously mentioned, the screen is composed of partial surfaces of planes, spheres, cylinders, and tori, as shown in Fig. 5. Such a uniquely shaped screen is made of fiberglass reinforced plastic (FRP) that has not only capability to reproduce complex shape but also enough rigidity to support itself.

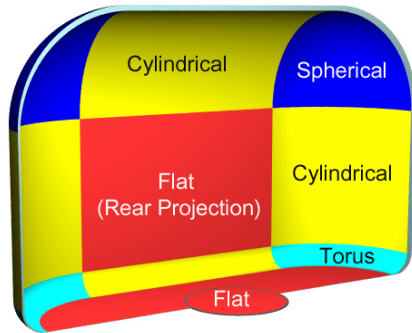

Fig. 5 Various surface elements that constitute the entire surface of the screen

Eight pairs of projectors are used to project stereoscopic images, the left-eye image and the right-eye image, onto the rear projection screen and the upper and lower cylindrical parts of the front projection screen. We used orthogonal linear polarized lights to project each image for the left and the right eye. To maintain the light polarization after it is diffused onto the front projection screen, we painted the front screen with gray paint mixed with aluminum powder. The rear projection screen is suitable for conserving polarization of light and has a rather high gain.

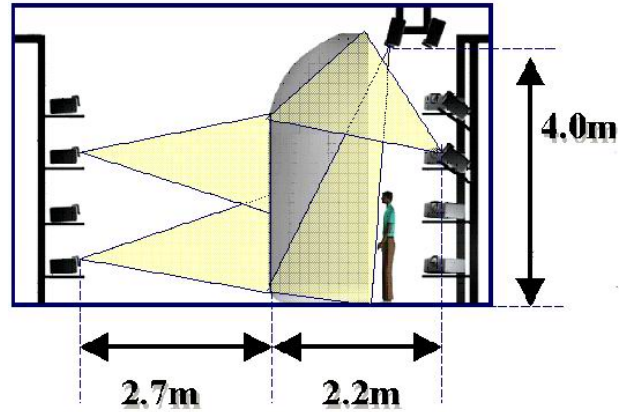

Fig. 6 Side view of the D-vision

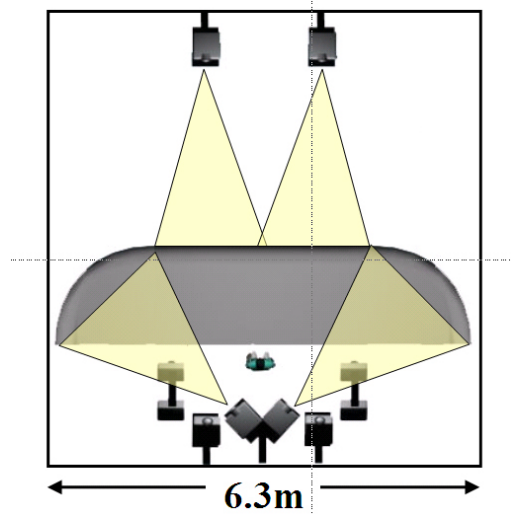

Fig. 7 Plan view of the D-vision

A high gain screen for rear projection diffuses the stronger light more parallel to the incoming light's direction than to other directions. This property is not suitable for edge blending because the blending ratio for incoming light from different directions depends on the viewing angle of an observer. However, we used a high gain screen because for us it was more important to use a stereoscopic display system. As shown in Fig. 6 and Fig. 7, the both front and rear projection system are selected in D-vision.

In order to achieve the seamless multi-projection image, the geometric correction, edge blending and real-time image processing hardware technologies [7] are the important parts to be developed. We solved these problems to make the one whole rendered image in D-vision. The geometrically corrected and edge blended image is projected on the screen through the image processing hardware real-timely by individual pixels converting. To explain these technologies in detail is beyond the purpose of this paper.



Fig. 8 PC cluster for parallel processing

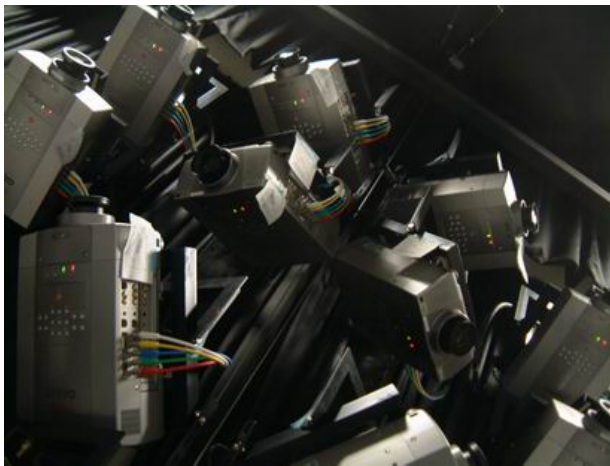

Fig. 9 Projector array for the peripheral eye area

### 3. Distributed Rendering with a PC cluster

In D-vision, we used a PC cluster to make the super-wide view angle and high-resolution 3D CG images. The PC cluster works like a super computer by connecting several computers with parallel processing. We illustrate the PC cluster in Fig. 8. In D-vision, scene images are divided into the sixteen areas for the distributed rendering in each PC that is connected to the each projector.

The eight areas which include the central view and up and down side of peripheral view are rendered by sixteen PCs for the stereoscopic viewing using polarized glasses. Total twenty-four PCs are used for the whole images including eight more PCs for the right and left side of peripheral view. The Fig. 9 shows the projector array for the peripheral area.

The PC cluster is composed of the common computer hardware. The components are the dual Pentium 800Mhz CPU, 512 MB memory and NVIDIA GeForce 2 Ultra graphic card. Either of the Windows2000 or Linux is

possible as the operating system. Actually we are upgrading the computers for the central view area. The high-speed network is required to enable the PC cluster. D-vision has two kinds of network cards. The one is 100Mbps Ethernet card. The other is Myrinet released by Myricom [8] for the PC cluster as the De Facto Standard. The Myrinet has the performance of full-duplex 2+2 Gbit/s data rate that compensates the distributed parallel system of the PC cluster.

We equipped the D-vision with OpenGL distributed rendering applications [9] based on WireGL [10] which was developed in the Stanford university. Because the modified WireGL supports the distributed rendering from the OpenGL command, the most of the 3D application are available in the D-vision.

### 4. Applications

We developed some applications working on the D-vision described as below. These interfaces reinforce the performance of the D-vision and help the user feel the high-immersion in the system by interaction with virtual world.

#### - Turntable

In the D-vision, we developed the Turntable as the locomotion interface for the virtual world navigation, as shown in Fig. 10. This device reinforces the immersion of the user by making it possible to navigate virtual space with his natural stepping on Turntable [11][12][13].

There are sensors below Turntable that send the pressure data to the computer. By checking the value of the each sensor, the computer calculates the direction of the user and rotates the Turntable to make him face to the front screen.

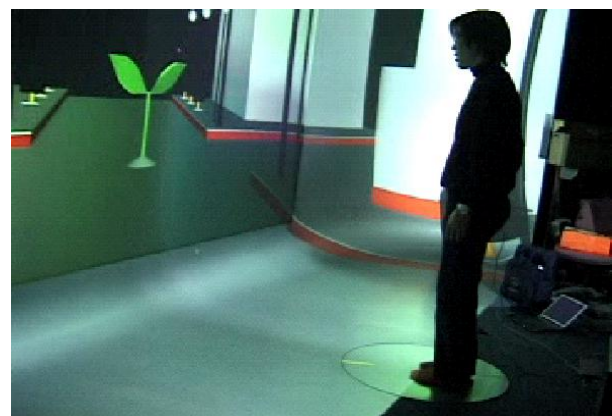

Fig. 10 Walking on the TurnTable

The user always faces to the screen directly by the

controlling of rotation of the turntable. For this reason, the viewer can walk to any direction infinitely with facing to front screen. In addition, the user can go forward and turn right and left freely and even look at side direction when walking forward cooperating with the head tracker device because the system can have two kinds of directional signal from both Turntable and head tracker device. The actual walking behavior makes viewer feel the high immersion of the D-vision with the high quality images.

- **The mapping image using photo image**

In Fig. 11, the construction of the virtual world is possible by using real photo images [14]. Texture mapping technologies is adopted to make the virtual space like real world with and the high resolution and super-wide view angle using real photos. We used the photo image taken by fish-eye lens camera to texture mapping on the surface of sphere object in virtual space. The user can experience the whole 360 degrees of the room space with Turntable interface. It is one of the easiest ways to make representation of real world.

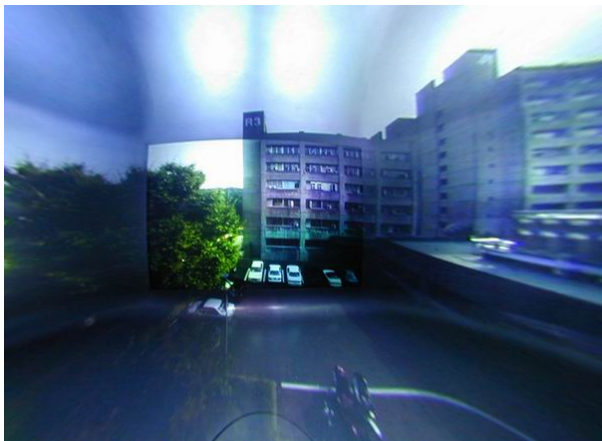

Fig. 11 The mapping image

- **Extension of WireGL**

It is possible to operate the application of the OpenGL in D-vision system based on the distributed rendering system, “WireGL” which is developed by Stanford University Computer Graphic Lab for the m x n tile-projection rendering. The original WireGL is developed not for the curved screens that have 180 degree FOV but for the plat tile-projection. In D-vision, we extended the application of the WireGL for the curved screen without distortion of the image on the curved screens (peripheral view of eye) by redefinition of the projection converting. By using the WireGL, we realized the fast rendering performance in our system and can use the former

OpenGL application without modification of the source(Fig. 10).

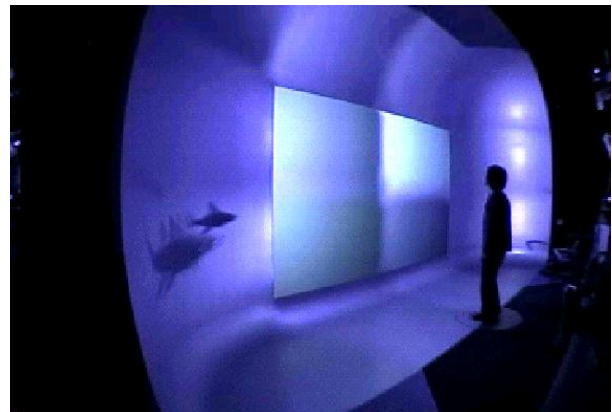

Fig. 12 The WireGL application

- **Big-SPIDAR**

One of the characteristics of our VE system is that user can experience the interaction with the virtual space through the Big-SPIDAR, string based force feedback interface(Fig. 13). The user can touch and manipulate the object in the virtual space with two hands.

This device reinforces the immersion of user through sense of touch and force feedback in the virtual space. The whole eight strings are installed to calculate the location of two hands and make proper force feedback to the hands. Four strings are behind of the curved screen and the other strings are backside of user at the frame of the front projectors. The equipments of the Big-SPIDAR, behind of the screen, are not recognized by user because the screen is not transparent.

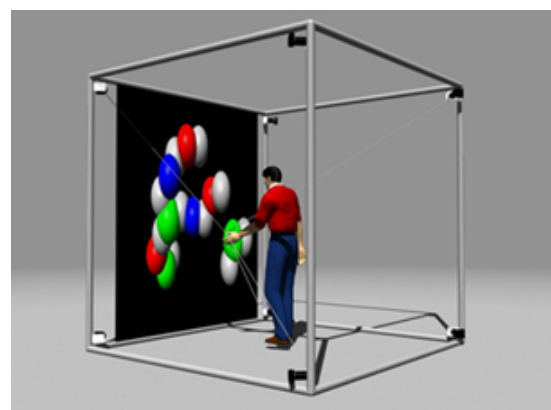

Fig. 13 Human Scale SPIDAR

- **Stereoscopic Viewing**

The stereoscopic viewing is possible in our system, with the orthogonal polarized lights and head tracker system.

The user who stands on the Turntable wearing polarized glasses can see the motion parallax and stereoscopic image. As in Fig. 14, the screens are divided two parts for the right and left eyes. The central view of eye and up and down side of area is double projected for the stereoscopic image. One array of the double projected images is synchronized with one of the side peripheral projection to avoid the incongruity in the border of the stereoscopic image.

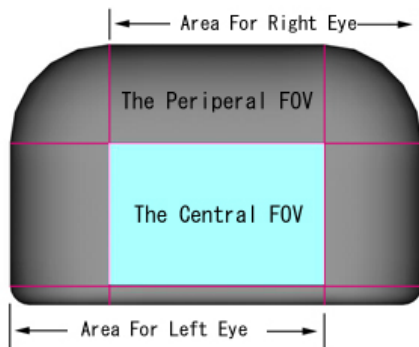

Fig. 14 The division of stereoscopic area in screens

### 5. Experiment for sense of presence

We investigated the effect of the peripheral FOV including the floor projection on the standing performance as the experiment of the sense of presence. We measured the data of subject when the room image is moved back and forth. The force plate of Kistler was used to get the pressure data of subject body sway.

- METHOD

Subjects are guided to the room without any image on the screen. They are said to just stand on the center of the system with comfort.

Step 1. Standing on the force plate for 60 seconds to check the stability of the experimental subject without any visual stimulus: No image is projected on the screen to verify the standing performance of the subject. Subjects are instructed to stand on the force plate looking at the front screen without deliberate movement of body and head during the experiment. And they will close their eyes for a moment to prepare case1(Fig. 15).

Step 2. When the experimental projection image is prepared, they are instructed to open their eyes: When they open their eyes, the animated room will start to move back and forth.

Step 3. When each case of the experiment is finished (during the cases), they are instructed to close his eye until next step.

Step 4. Do next case of experiment as shown in Table.1.

Table. 1

Start	To Check the standing performance
Case 1	Central FOV Screen
Case 2	Central + Peripheral FOV Screen

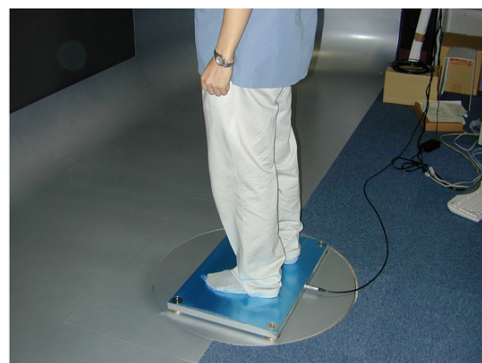
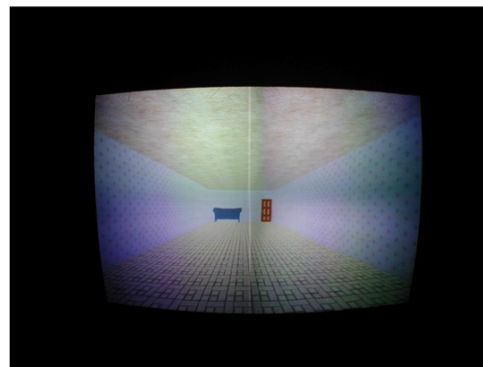

Fig. 15 Top: Center + Peripheral FOV, Middle: Central FOV, Bottom: The subject facing with front screen,

Apparatus. We used the portable multi-component Force Plate for Biomechanics of Kistler(Fig. 16). The device can

measure the 3 orthogonal components of a force( $F_x$ ,  $F_y$ ,  $F_z$ ) acting from any direction on the top plate. Here, we just used the  $F_x$  component of user body weight force because the room image moves along the X-axis. The X-axis is a direction to the front screen. The size of the force plate is 0.6m x 0.4m.

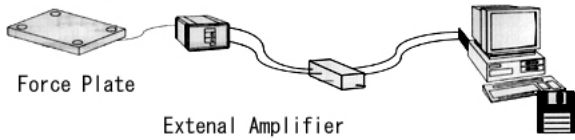

Fig. 16 The Force Plate system of Kistler

## RESULT

We experimented three subjects to verify the effects of the peripheral view area for the immersion. One example of the dispersion graphs of body weight is shown in Fig. 17.

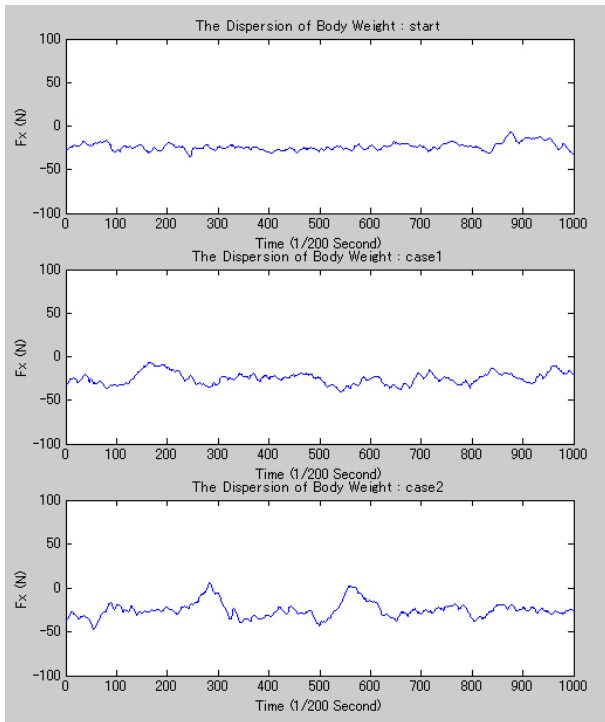

Fig. 17 The Dispersion Graphs of body weight of Subject A (top: Start, middle: Case1, bottom: Case2)

The data was analyzed by the variance of the value to get the degree of the body sway influenced by the animated image on the screen.

$$V = \frac{1}{n} \sum_{i=1}^n (x_i - \bar{x})^2, \text{ where } \bar{x} = \frac{1}{n} \sum_{i=1}^n x_i$$

The calculated variances are listed below.

Table. 2

	Start	Case1	Case2
Subject A	30.79	40.75	57.17
Subject B	4.46	6.83	7.30
Subject C	7.47	13.36	15.30

The variances of the every case2(Central + Peripheral FOV screen) are bigger than the value of the case1(Central FOV screen) showing the effects of the peripheral view area. This result indicates the important role of the peripheral view area in the VEs.

As the future works, we are planning to verify the immersion of user further with the stereoscopic image and force feedback sense. We are interested in the effect of the merging of sensation for the immersion in virtual space.

## 6. Conclusion

We developed an immersive multi-projection system which has hybrid screen system with following these applications; (1) Turntable as the locomotion interface for D-vision, (2) the distributed rendering PC cluster system that is connected based on the WireGL for the 16 divided areas, (3) Big-SPIDAR, string based force feedback interface for interaction with the virtual space, and (4) the stereoscopic viewing with head tracker system.

In order to show the high quality image for the central and peripheral view angle of eye and provide the high immersion experience, we developed these applications that are connected with our system. These applications reinforce the immersion of the user with providing the more realistic virtual space.

The further direction of this study is to upgrade the system performance, and at the same time, we need to verify the efficiency of this multi-projection display system that is composed of other supporting interfaces by observing the immersion of viewer. We also interested in the developing of application tool in the education and design field using our system in the future.

## References

1. C. Cruz-Neira, D. J. Sandin and T. A. DeFanti, "Surround-Screen Projection-Based Virtual Reality: The Design and Implementation of the CAVE", proceedings of ACM SIGGRAPH'93, pp.135-142, 1993.
2. Michitaka Hirose, Tetsuro Ogi, Shohei Ishiwata and Toshio Yamada, "Development and Evaluation of Immersive Multiscreen Display "CABIN"", The transactions of the Institute of Electronics, Information and Communication Engineerings D-II, Vol. J81, No. 5, pp.888-896, 1998.
3. Toshio Yamada, Hideki Tanahashi, Tetsuro Ogi and Michitaka Hirose, "Development of Fully Immersive 6-Screen Display "COSMOS" and Evaluation of Virtual Space Navigation", Transactions of the Virtual Reality Society of Japan, Vol. 4, No. 3, pp.531-538, 1999.
4. Wataru Hashimoto and Hiroo Iwata, "Ensphered Vision: Spherical Immersive Display using Convex Mirror", Transaction of the Virtual Reality Society of Japan, Vol. 4, No. 3, pp. 479-486, 1999.
5. Nobuyuki Shibano, Tomoyuki Hatanaka, Hiroyasu Nakanishi, Hiroshi Hoshino, Ryuichiro Nagahama, Kazuya Sawada and Junji Nomura, "Development of VR Presentation System with Spherical Screen for Urban Environment Human Media", Transaction of the Virtual Reality Society of Japan, Vol.4, No. 3, pp.549-554, 1999.
6. L. Bouguila, et al., "New Haptic Device For Human Scale Virtual Environment: Scaleable-SPIDAR", ICAT'97, pp.93-98, Tokyo, Dec. 1997.
7. M. Yamasaki, T. Minakawa, H. Takeda, S. Hasagawa, and M. Sato, "Technology for seamless multi-projection onto a hybrid screen compose of differently shaped surface elements", IPT 2002 (7<sup>th</sup> Annual Immersive Projection Technology Symposium), Orlando, FL, USA, Mar. 2002.
8. N. J. Boden, D. Cohen, R. E. Felderman, A. E. Kulawik, C. L. Seitz, J. N. Seizovic and Wen-King Su: "Myrinet: A Gigabit-per-Second Local Area Network", IEEE Micro, Vol. 15, No. 1, pp.29-36, 1995.
9. Ikunao Tada, Shoichi Hasegawa, Naoki Matsumoto, Atsushi Toyama and Makoto Sato, "Constructing Distributed Rendering System for Multi Screen With PC Cluster", Technical report of IEICE, MVE2001-140, pp.19-24, 2001.
10. G. Humphreys, M Eldridge, Ian B., G Stoll, M Everett and P Hanrahan, "WireGL: A Scalable Graphics System for Clusters", In Proceedings of SIGGRAPH2001, 2001.
11. Yoshinori Ejima, Shoichi Hasegawa, Yasuharu Koike and Makoto Sato, "Development of locomotion interface with TurnTable for human-scale, virtual environment", In Proceedings of the 6th VRSJ Annual Conference, pp.87-90, 2001.
12. Laroussi Bouguila, Makoto Sato, Shoichi Hasegawa, Hashimoto Naoki, Naoki Matsumoto, Atsushi Toyama, Jelel Ezzine, Dalel Maghrebi, "A New Step-in-Place Locomotion Interface for Virtual Environment With Large Display System", SIGGRAPH2002 Conference Abstracts and Applications, p.63, 2002.
13. Atsushi Toyama, Masaru Iwashita, Shoichi Hasegawa, Naoki Hashimoto, Yasuharu Koike, Makoto Sato, "Development of locomotion interface for immersive virtual environment with stepping", In proceedings of the 7th VRSJ Annual Conference, 2002.
14. Tomoaki Morozumi, Shoichi Hasegawa and Makoto Sato, "Projection of Wide FOV Image to a Multi Screen Display", Technical report of IEICE, MVE 2001-139, pp.13-18, 2002.