

Arm Type Haptic Human Interface: Sensor Arm

A. NAKAI*, Y. KUNII**, H. HASHIMOTO*, and F. HARASHIMA*

*Institute of Industrial Science, University of Tokyo
7-22-1 Roppongi, Minato-ku, Tokyo 106, Japan.

**Faculty of Science and Engineering, Chuo University
1-13-27 Kasuga, Bunkyo-ku, Tokyo 112, Japan.

{*nakai, kunii, hideki, fumio*}@vss.iis.u-tokyo.ac.jp

Abstract

This paper presents a new type of human interface with force feedback attached to an arm, which we named *Sensor Arm*. The Sensor Arm can be utilized as an interface for interactive communication with the virtual world and as a master manipulator of a tele-operation system. The number of degrees-of-freedom (DOF) of the Sensor Arm is seven, which is the same DOF of a human arm. Angle and torque of each joint can be measured. Moreover, in this system, force feedback can be realized at each joint of the human arm. To measure human force a new type of force sensor system is used in the Sensor Arm system. The structure of the Sensor Arm system and the experimental results are shown.

Key words : Human Interface, Force Feedback, Virtual Reality, Tele-operation, Force Sensor

1 Introduction

Human interface is always present between a man and a machine when there are communication between them. A key-board, display, mouse or joystick are the most typical and popular devices used for human interface. They are simple and easy to use, but they also require an user-unfriendly language or motion, such as the computer commands or keyboarding to operate a machine system. This causes a lot of trouble to the operator. The operators must be trained to acquire these particular abilities for using the machine systems. However, the recent rapid advancement of the computer technology has opened a new gate for an exciting and challenging research field, so called Virtual Reality (VR) or Artificial Reality. In the research field of VR, many types of new human interfaces have been developed. Some of these new interfaces, for example the Head Mount Display (HMD) [1], or the Data Glove [2], are user-friendly human interfaces. Using these interfaces,

an operator can communicate with a virtual world with a natural motion or language, and the computer world comes close to us.

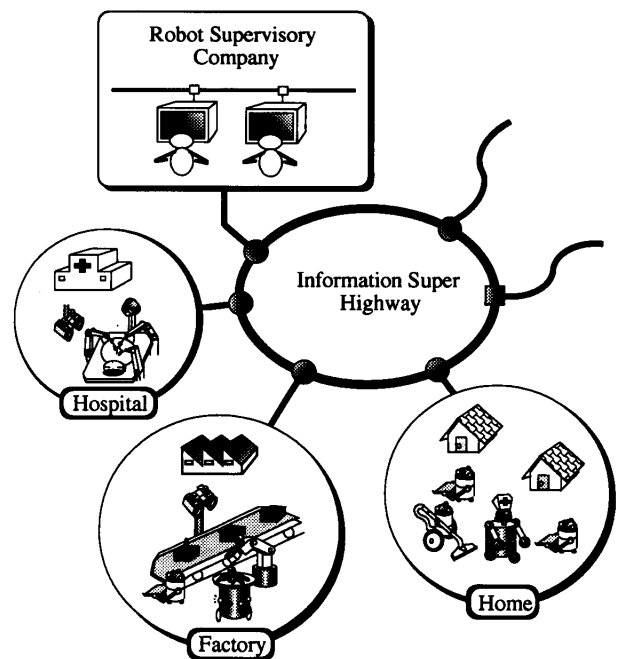

Figure 1: Robotic Network Systems.

Human interface systems design is a critical issue in tele-operation and tele-robotics systems. In tele-operation systems or VR systems, the task performance can be improved by providing force information of a remote site or a virtual world to the human operator [3], [4]. HMD and Data Glove can provide visual or force information from the human operator to the virtual world, however, the operator can not feel the force of the virtual world. Therefore, producing force feedback is necessary to design a human interface system.

In this paper, a human interface for "Robotic Network Systems" is presented. Robotic Network Systems (RNS) is the system proposed by our labora-

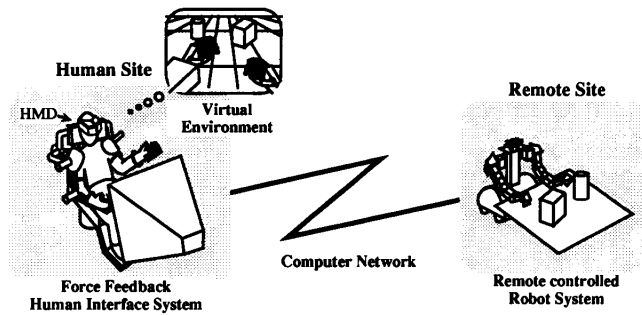

Figure 2: Cockpit in the RNS.

tory, which is a human-machine cooperative system via computer network using tele-existence technique (Figure 1) [5] [6]. The robots are popular now, but they are present only in some limited places. In the RNS, however, their activities can be broadened to various areas in our society such as in houses, hospitals, factories, construction sites or amusement parks since several kinds of robots can be controlled from a cockpit in a remote site through the Computer Network (Figure 2). There are three main challenges for accomplishing the RNS: development of an easy-to-use human interface, development of a humanoid robot, and construction of the Information Super Highway similar to the B-ISDN.

In the RNS, human operator with human interface devices in a cockpit controls the robots, and he/she gets various information of a remote environment using Virtual Reality techniques, for example HMD and human interface with force feedback. Equipped with these interfaces, the operator can control the robot at the remote site with the sensation of presence in the 'remote site'.

We are making a new type of human interface with force feedback to be attached to an arm, which is called as *Sensor Arm*. The Sensor Arm can be utilized as an interface for interactive communication with the virtual world and as a master manipulator of a tele-operation system. In the Sensor Arm system, angle and torque of each joint of the human arm can be measured, and force feedback can be realized at each joint. A new design of the force sensor system is used in the Sensor Arm system. The structure and the experimental results of the Sensor Arm are presented in this paper.

2 Sensor Arm

2.1 Design of a Haptic Interface

In tele-existence systems, since realizing a complete sensation of presence in the remote site is an essential component, a fundamental requirement in the design of the human interface system is the reproduction of the adequate sensor signals which will be acquired by the remote robot.

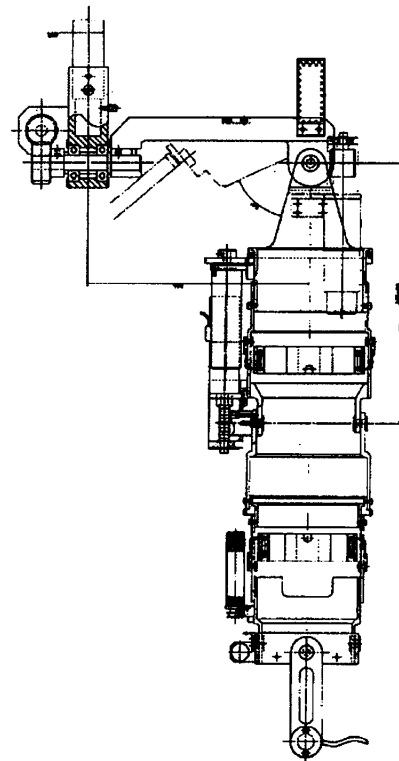

Degrees of Freedom	7 DOF	
Length	Upper Arm	240 ± 15 mm
	Forearm	285 ± 20 mm
	Total	635 ± 35 mm
Weight	(with the motors, etc.) about 6 kg	

Figure 3: The structure of the Sensor Arm.

In addition, a new scheme for cooperation between man and machine, based on human knowledge is proposed in the RNS. The intelligent cooperation scheme is constructed using the advanced human physical skills which are a fundamental human ability. The construction of these cooperative scheme brings for the first time the necessity of measuring the human movement. These data are used in the algorithm of used to achieve a primitive intelligence.[11].

Considering the above requirements, the constructional requirements to be considered on the design of a haptic interface system are [7], [8]:

- the isomorphism,
- the motion range capability,
- the accommodation for human hand size variability.

Moreover, it is important for a human operator to move freely in a natural manner, and not to feel the weight of the interface system.

The isomorphism is realized when the interface for communication with the virtual world has the same 'shape' of the human being. So, a virtual arm

Joint (show Figure 5)		Motion Range (deg)
shoulder	flexion-extension (θ_1)	$-30 \sim +150$
	abduction-adduction (θ_2)	$\pm 0 \sim +50$
upper arm	external-internal rotation(θ_3)	$-60 \sim +60$
elbow	flexion-extension (θ_4)	$\pm 0 \sim +90$
forearm	pronation-supination (θ_5)	$-90 \sim +90$
wrist	radial flexion-ulnar flexion(θ_6)	$-15 \sim +15$
	flexion-extension (θ_7)	$-60 \sim +60$

Table 1: Motion range of each joint.

can move in a natural manner with the data measured by the system.

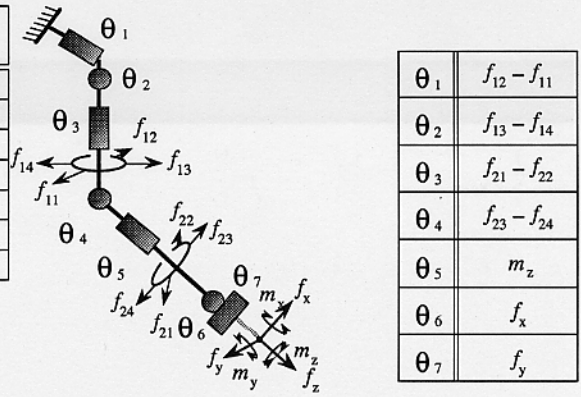

Figure 5: The degrees of freedom of the Sensor Arm.

movement (θ_4), 1 DOF at the forearm (pronation-supination movement (θ_5)), and 2 DOF at the wrist (radial flexion-ulnar flexion (θ_6) and flexion-extension (θ_7) movements) [9].

The motion range of each joint is shown in Table 1. The motion ranges of the Sensor Arm are not entirely correspondent to those of human arm. Especially, the motion range of the joint θ_2 is much narrower than that of human arm. The limit is caused by the structure of the system, and is one problem to solve in the future.

Furthermore, the lengths of the upper arm and the forearm can vary corresponding to the operator's arm (the length of the upper arm; $240 \pm 15[mm]$, that of the forearm; $285 \pm 20[mm]$. Total length from the shoulder to the end of the Sensor Arm; $635 \pm 35[mm]$).

2.2.2 Functional Feature

The force feedback at each joint is realized by the DC servo motors. The spur gears are used to transmit torque from the actuator to the joints of the upper arm and the forearm, while the worm gears are used at the joints of the shoulder and the elbow. The torque of the DC servo motors on the wrist are transmitted to the joints by the wire transmission (radial flexion-ulnar flexion) and the rubber belt transmission (flexion-extension). The angle of each joint is measured by the optical encoder connected directly with the DC servo motor. In addition, the torque of each joint is measured by three force/torque sensors; one is the 6-axis force/torque sensor located at the end of the Sensor Arm and the others are the new type of force sensor systems located on the upper arm and the forearm. The structure of the new type of the force sensor system is described in the following section.

The photo of the Sensor Arm is shown in Figure 4. The actuators and the strain gauges are not included in the figure. The Sensor Arm is fixed on the pole. The human operator sits at the side of the sys-

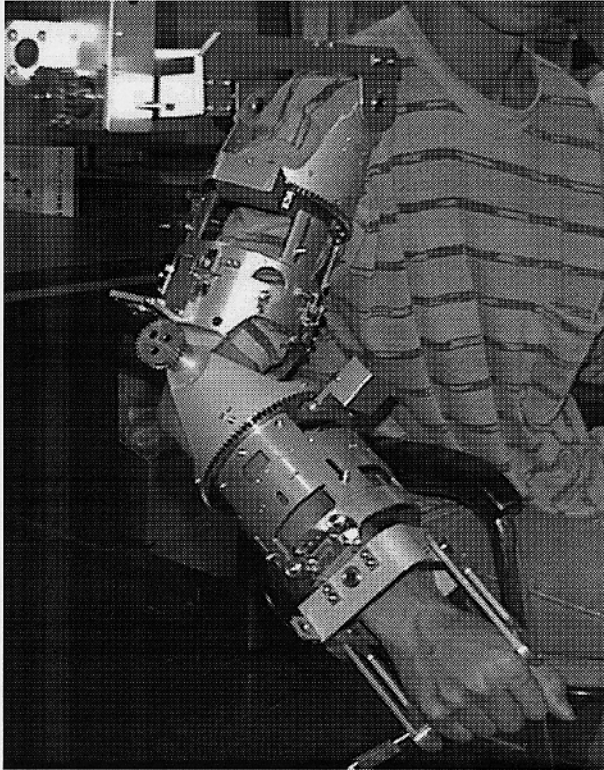

Figure 4: The photo of the Sensor Arm.

2.2 Structure of the Sensor Arm

To achieve the above requirements, the Sensor Arm system is designed as follows.

2.2.1 Constructional Feature

The Sensor Arm is an exoskeleton-type human interface device, which wraps up the whole arm. Figure 3 shows the structure of the Sensor Arm with 7 degrees-of-freedom (DOF) from shoulder to wrist which is the same structure present in a human arm; there are 2 DOF at the shoulder (flexion-extension (θ_1) and abduction-adduction (θ_2) movements), 1 DOF at the upper arm (external rotation-internal rotation (θ_3)), 1 DOF at the elbow (flexion-extension

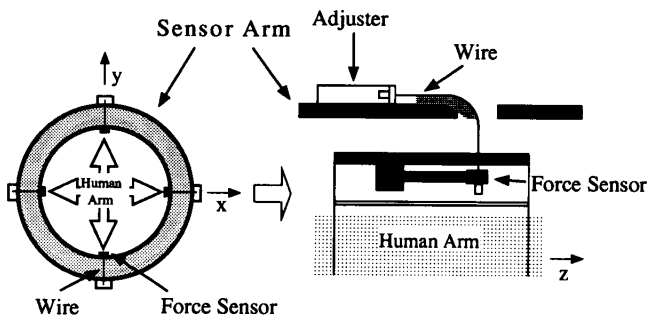

Figure 6: The structure of force sensor system.

tem and attaches it to his/her arm. He/She grasps the bar at the end of the Sensor Arm and his/her arm is held by the upper arm and the forearm. The Sensor Arm system including the DC servo motors, the encoders and the strain gauges weighs about 6 kg.

3 Force Sensor System

In the Sensor Arm system, the torque of each joint is measured by two types of force/torque sensors (Figure 5). One is the 6-axis force/torque sensor installed in the bar at the end of the Sensor Arm which a human operator grasps. It can measure both the force along the x , y and z -axes and the moment around three axes. The torque of the forearm joint (θ_5) is calculated from the moment around the z -axis, and the torque of the wrist joints (θ_6 , θ_7) are calculated from the force along the x and y -axes.

The other sensor is a new type of force sensor system on the upper arm and the forearm. These sensors can measure the force on the plane perpendicular to the Sensor Arm. The force sensor system at the upper arm can measure the torque of the shoulder joints (θ_1 , θ_2), and the torque of the rest (θ_3 , θ_4) is calculated by the force sensor system at the forearm.

3.1 Structure of Force Sensor System

A new type of force sensor system was designed for the Sensor Arm system. The structure of the force sensor system is shown in Figure 6. It consists of three parts: the concentric part inside the Sensor Arm, four force sensors fixed inside of the concentric part, and the adjusters of the wire tension fixed to the outside of the Sensor Arm. The wire used in the force sensor system is a particular one which is constructed spinning the fishing lines for *ayu* fishing difficult to be deformed.

A rubber tube of a tonometer is wrapped around a human arm at the same part of the force sensor system. The tube is filled with air by a pump to fix the human arm to the concentric part of the force

sensor system. The wire is strained with a constant tension from the end of the force sensor to the adjuster. Four strain gauges are installed on the both sides of the force sensor to measure the force.

Each force sensor measures a positive quantity when the wire tension increases. The software cuts off the negative quantities of the force after gravity correction. The difference between the outputs of the force sensors on each opposite side indicates the force along the x -axis or y -axis. The force along the z -axis and the moment around the z -axis are compensated in order to equalize the outputs of two force sensors on the opposite side. These force and moments are measured by the 6-axis force/torque sensor. Thus, the force sensor system can measure the force only on the x - y plain. The features of the force sensor system are summarized as follows:

- Compact style,
- Easy operation to adjust zero-point of the force sensor because one force sensor measures the one direction of the force,
- Capability to compensate the force along the z -axis and the moment around the z -axis.

3.2 Force Sensor Experimental Result

In order to evaluate the characteristics of the designed force sensor system, an experimental force sensor system with the same structure used in the Sensor Arm was constructed. The system was fixed on the table such that the z -axis of the force sensor system remained parallel to the ground. In the experiments, the calibration of the force sensor and the gravity correction were not carried out.

Figure 7 shows the experimental results. In the first experiment, a circular force was applied with the operator arm, which is fixed to the concentric part. The outputs of the force sensors were measured and the trajectories of the correspondent force vectors were generated (Figure 7(a)). In the second one, a transverse force was applied in a similar manner. Again, the outputs of the force sensors were measured and the trajectories of the correspondent force vectors were generated (Figure 7(b)). In the last one, a moment around the z -axis was applied. The outputs of all sensor were almost equal and were compensated. Almost no force was measured in such a case (Figure 7(c)).

4 Control System

4.1 Control Scheme

The control schemes are illustrated in Figure 8. There are two control schemes of the Sensor Arm

system, one is used in the case that the system is a master manipulator of a tele-operation system (Figure 8 (a)), and the other is used in the case that the system is an interactive communication interface with the virtual world (Figure 8 (b)).

The main control scheme of the Sensor Arm system is the same in both cases. A virtual impedance (VI) model is used to generate the reference angle for the Sensor Arm motors using the sum of two forces: the force from the operator arm, and the force from the remote site or the virtual world. VI is composed of a virtual spring, K_v , a virtual damper, D_v , and a virtual mass, M_v [10]. When a force is applied to the virtual mass, the position of the virtual mass is modified according to the VI dynamics equation is as follows:

$$F = M_v \ddot{\theta} + D_v \dot{\theta} + K_v \theta$$

where F is the force detected at the virtual mass and θ is the angle of the virtual mass. Considering VI in the frequency domain, the transfer function of VI acts as a second order low pass filter to convert the force into the angle. Thus the angle is always smooth even if the force contains high frequency components, and it is efficient for the communication through the Network with variable time delay.

In the case that the Sensor Arm system connected to the virtual world, the Dynamic Force Simulator (DFS) [5], [11], which is a virtual reality simulator for a dexterous haptic interface, is used. The DFS is a simulator of a force flow between a human operator and an object in the virtual world, and generates the ideal force to the virtual object and the appropriate reaction force to the human operator. The force from a human operator to an object passes through the contact model and the friction model, and is divided into two forces: one affects the object motion and the other doesn't affect. In the case of the force that affects the object motion, the reaction force is calculated with the dynamics of the object, the friction model and the contact model through which the force from a human flows to an object.

4.2 Hardware

The structure of the control system is shown in Figure 9. The motion control of the Sensor Arm is realized by using the Pentium 166MHz PC with Linux 2.0.27 operating system. The force/torque information from the force/torque sensors are sent to the controller through the amplifiers and two AD boards. The data of the optical encoder are sent to the controller through two CNT boards. The controller generates the motor control signals from the force/torque and angle data, and the control signals are sent through the DA board and the amplifiers to the DC servo motors. All boards are connected to the ISA bus of the controller.

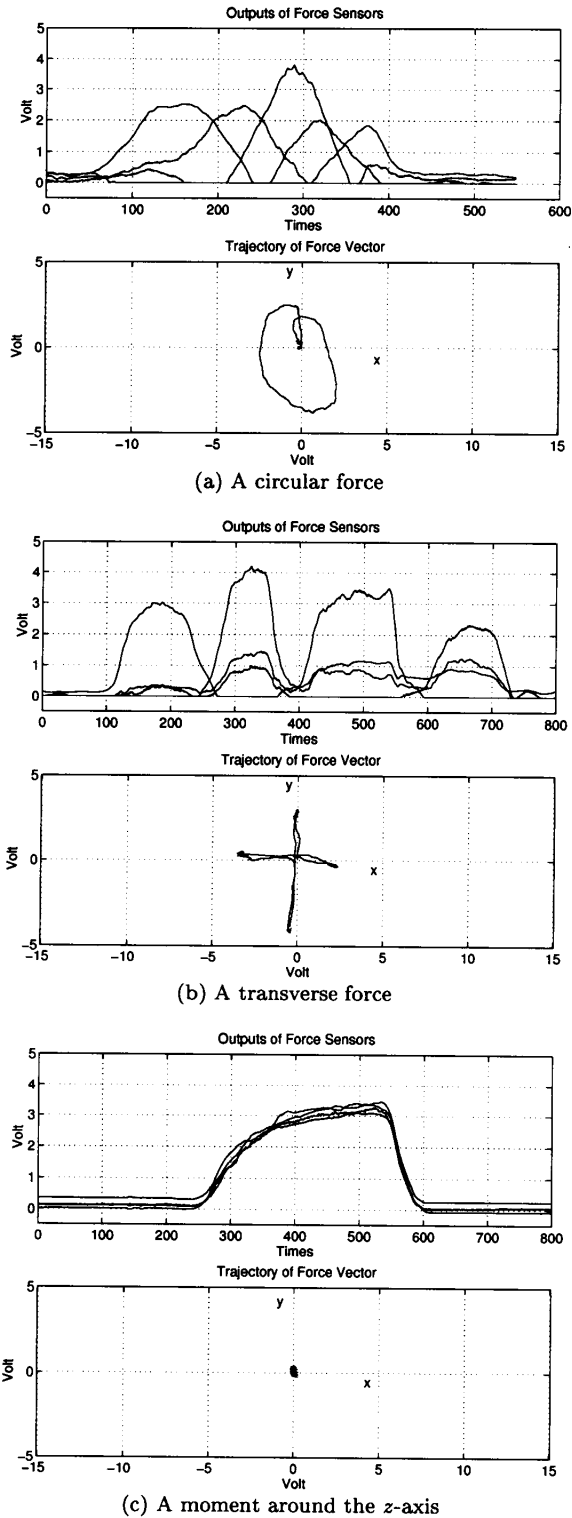
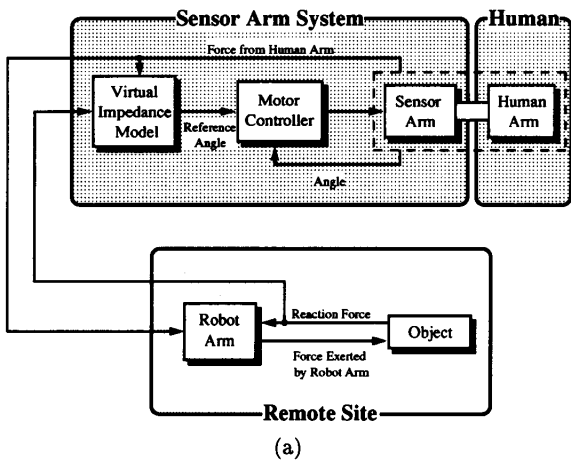
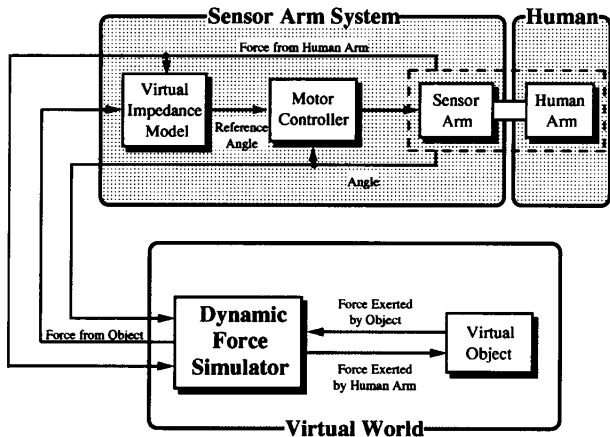

Figure 7: Experimental results of force sensor system (without calibration).



(a)



(b)

Figure 8: The control scheme of the Sensor Arm system: in the case that system is used as (a) a master system of tele-operation system, and (b) an interactive communication interface with the virtual world.

The DFS is also realized by using the controller, and the virtual environment is constructed on Silicon Graphics workstation IMPACT 10000. The Silicon Graphics workstation communicates with the controller through Ethernet, and receives the Sensor Arm and virtual object data from the controller. The prototype of the virtual environment is illustrated in Figure 10. Since a hand system is not included in the Sensor Arm system, an operator can not grasp and lift up an object in the virtual environment. So, for the testing the system there are a wall and a pillar, which the operator can touch or tap with the Sensor Arm in the virtual environment.

The maximum frequency with which a typical human hand can transmit motion commands to the haptic interface is 5-10 Hz while it is required that the position and force feedback signals are presented to the human interface at a frequency not less than 20-30 Hz. If the force feedback is provided at about 300 Hz, the high frequency low amplitude force commands such as a tool chatter at the slave end can be

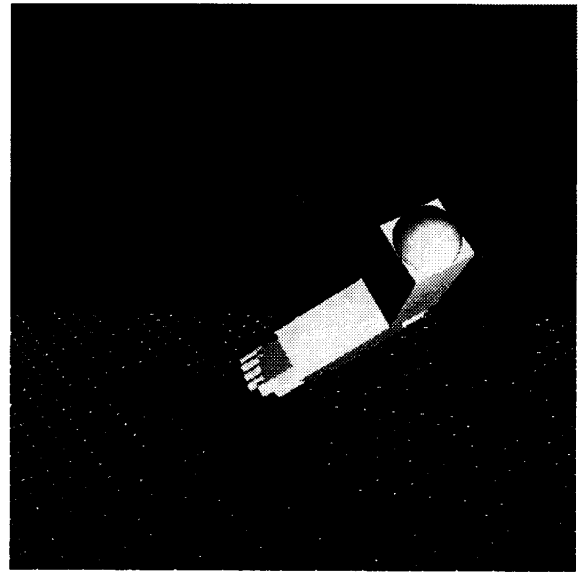

Figure 10: Computer Graphics.

felt. However, the human hand can not discriminate between two force signals at frequencies above 320 Hz and hence perceived as just vibrations [8], [12].

In the Sensor Arm system, the goal frequency is about 40 Hz. The system should be constructed to be fast as possible, however, the high frequency vibration is not considered.

5 Experimental Results

The data of the fundamental experiments with the Sensor Arm are shown in Figure 11. In the experiments, the new type of force sensor system at the forearm was used to measure the torque of the joint, and the motor at the joint θ_3 was controlled. The force sensor was taken off from the Sensor Arm and fixed to the ground. (It means that the Sensor Arm is not 'wore' by any user during the experiments.) A sampling time of 3ms is used in the programs. Figure 11(a) shows the angle of the joint θ_3 controlled by the motor (solid line) and the reference angle calculated from the torque of the joint (dot line). Note the very close tracking of the reference angle. The angle of the joint θ_3 is limited from -60 deg to 60 deg in the mechanical stopper and in the software (see Table 1). Figure 11(b) shows the torque of the joint measured by the force sensor system (solid line) and the angle of the joint (dot line).

6 Conclusion

The paper has presented the design of the Sensor Arm which is a 7 DOF human interface with force feedback. The Sensor Arm is used as an interface for interactive communication with a virtual world or a remote site. In addition, the new type of the force

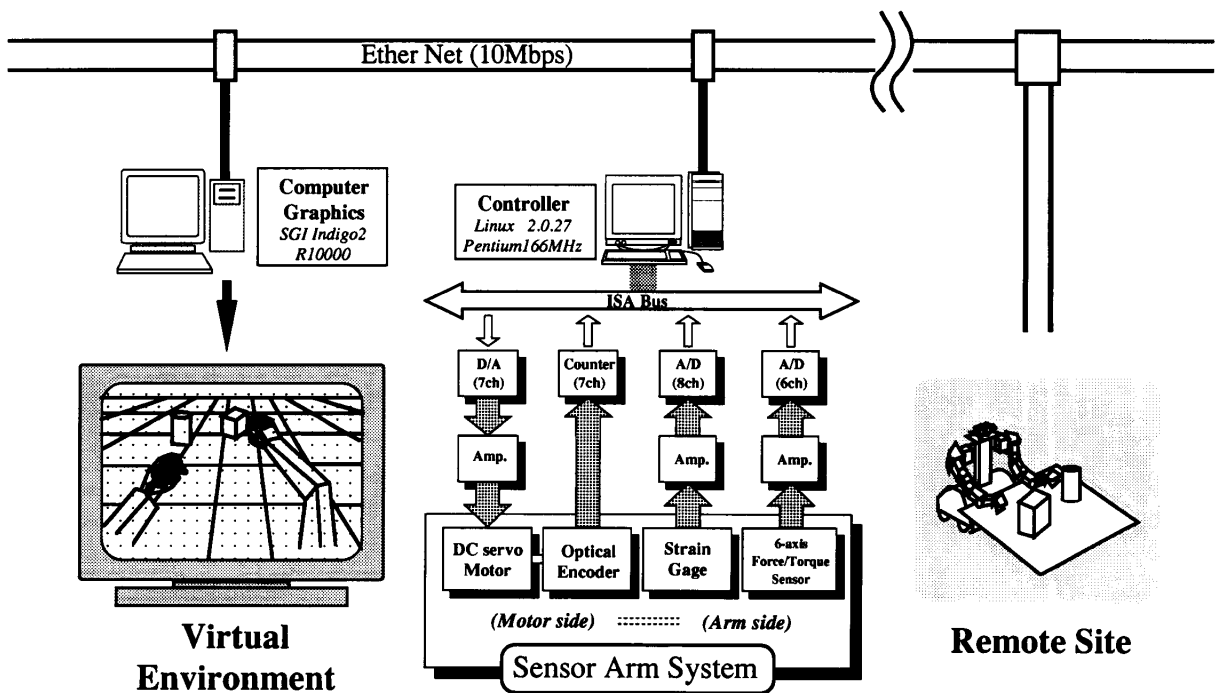
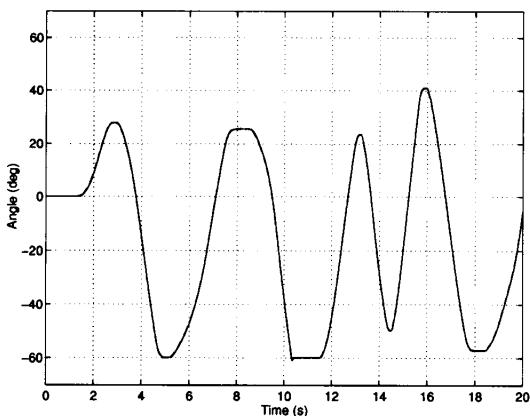
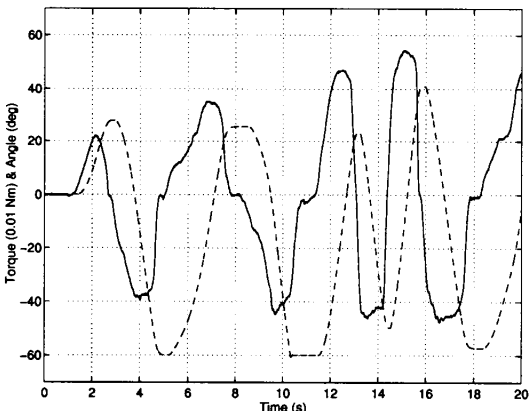

Figure 9: The structure of control hardware.



(a) Angle (solid line) and reference angle (dot line).



(b) Torque (solid line) and angle (dot line) of joint.

Figure 11: Experimental results

sensor system to be used in the Sensor Arm has been proposed and the system efficiency has been evaluated by the experiments. The experimental tests for 1 DOF have been performed, its results were shown in the paper.

The Sensor Arm system will be integrated soon, and connected to the virtual world constructed using the Silicon Graphics workstation through the Ethernet.

In the future, the system will be connected to the Sensor Glove II, which is the glove type human interface with 20 DOF [13], and the 27 DOF human interface device to be attached to an whole hand-arm will be constructed. Using this device, we can perform various task in the virtual space. Moreover, the task data of human hand measured from the device may be utilized for analysis of human movement and achievement of the intelligent cooperative scheme proposed in the RNS.

References

- [1] M. McKenna, D. Zeltzer, "Three Dimensional Visual Display Systems for Virtual Environments", *Presence*, Vol.1, Number.4, pp.421-458, Fall 1992.
- [2] D.J. Sturman, D. Zeltzer, "A Survey of Glove-based Input", *IEEE Computer Graphics & Applications*, pp.30-39, 1994.1.
- [3] S. Lee, B. Bekey, A.K. Bejczy, "Computer Control of Space-Borne Teleoperators with Sensory Feedback", *Proceedings of the 1985 IEEE International Conference on Robotics and Automation*, pp.205-214, 1985.

- [4] R.J. Anderson, M.W. Spong, "Bilateral Control of Teleoperators with Time Delay", *IEEE Transactions on Automation Control*, Vol.34, No.5, pp.494-501, 1989.
- [5] Y. Kunii, H. Hashimoto, "Virtual Environment for Haptic Interface in Robotic Network System", *Proceedings of the 1996 IEEE International Conference on Robotics and Automation*, pp.545-550, 1996.
- [6] S. Tachi, H. Arai, T. Maeda, "Tele-Existence Master Slave System for Remote Manipulation", *Proceedings of the International Workshop on Intelligent Robots and Systems IROS'90*, pp.343-348, 1990.
- [7] M. Bergamasco, "Design of Hand Force Feedback Systems for Glove-like Advanced Interface", *IEEE International Workshop on Robot and Human Communication ROMAN'92*, pp.286-293, 1992.
- [8] K.B. Shimoga, "A Survey of Perceptual Feedback Issue in Dexterous Telemanipulation:Part I. Finger Force Feedback", *Proceedings of Virtual Reality Annual International Symposium VRAIS*, pp.263-270, 1993.
- [9] M. Bergamasco, B. Allotta, L. Bosi, L. Ferretti, et al., "An Arm Exoskeleton System for Teleoperation and Virtual Environments Applications", *Proceedings of the 1994 IEEE International Conference on Robotics and Automation*, pp.1449-1454, 1994.
- [10] K. Furuta, K. Kosuge, Y. Shinote, H. Hatano, "Master-slave manipulator based on virtual internal model following control concept", *Proceedings of the 1987 IEEE International Conference on Robotics and Automation*, pp.,567-572, 1987
- [11] H. Hashimoto, M. Buss, Y. Kunii, F. Harashima, "Intelligent Cooperative Manipulation System Using Dynamic Force Simulator", *Proceedings of the 1994 IEEE International Conference on Robotics and Automation*, pp.2598-2603, 1994.
- [12] K.B. Shimoga, "A Survey of Perceptual Feedback Issue in Dexterous Telemanipulation:Part II. Finger Touch Feedback", *Proceedings of Virtual Reality Annual International Symposium VRAIS*, pp.271-279, 1993.
- [13] Y. Kunii, Y. Nishino, T. Kitada, H. Hashimoto, "Development of 20 DOF Glove Type Haptic Interface Device -Sensor Glove II-", *Proceedings of Advanced Intelligent Mechatronics AIM'97*, 1997.